



---

Richter Optica

[info@richter-optica.com](mailto:info@richter-optica.com)

---

Instructions for:  
S6-DL, S6-TS, S6-SPS, S6-ILS2 Models

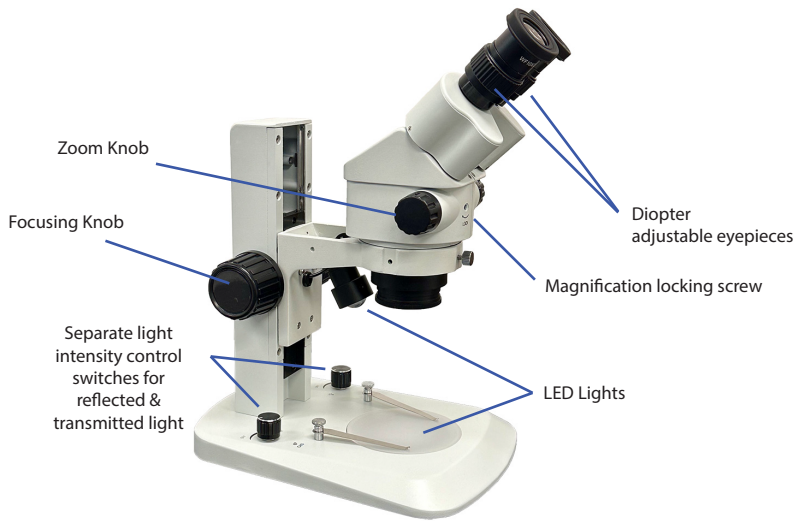

S6-DL

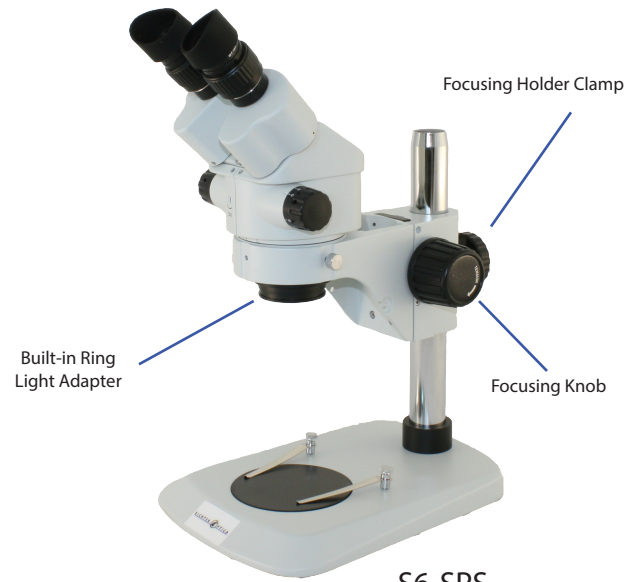

S6-SPS

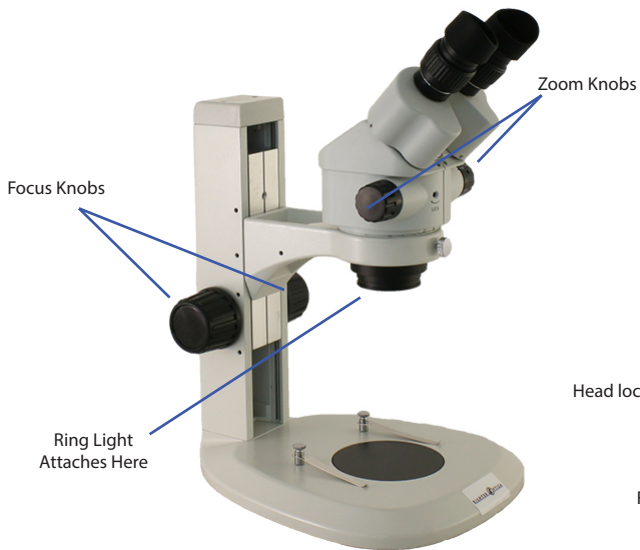

S6-TS

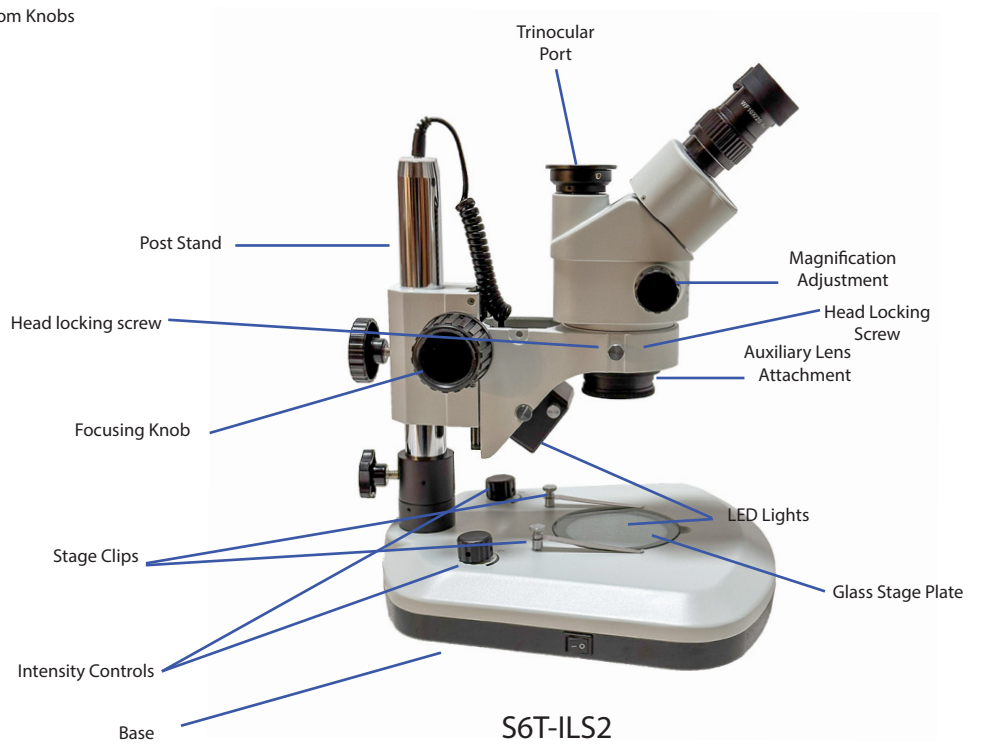

S6T-ILS2

Thank you for your purchase of a Richter Optica S6 stereo microscope. The information in this manual is provided to answer most questions that can arise when operating your microscope and to help you avoid unnecessary maintenance expenses in the future. Based on your microscope purchased, the stand may look slightly different.

Please carefully read instructions before operating microscope. Nomenclature used to describe components and controls are identified on opposite page.

## **UNPACKING**

Do not discard styrofoam container or packing materials until you are sure shipment is complete and undamaged (retain styrofoam shipping container to store your microscope when it is not in use). Remove all tape and packing material used to protect microscope during shipment. Make certain lens surfaces do not come in contact with dirt, fingerprints or oil. Damage of lens surfaces occur when they come in contact with such contaminants, and image quality is reduced.

## **ASSEMBLY**

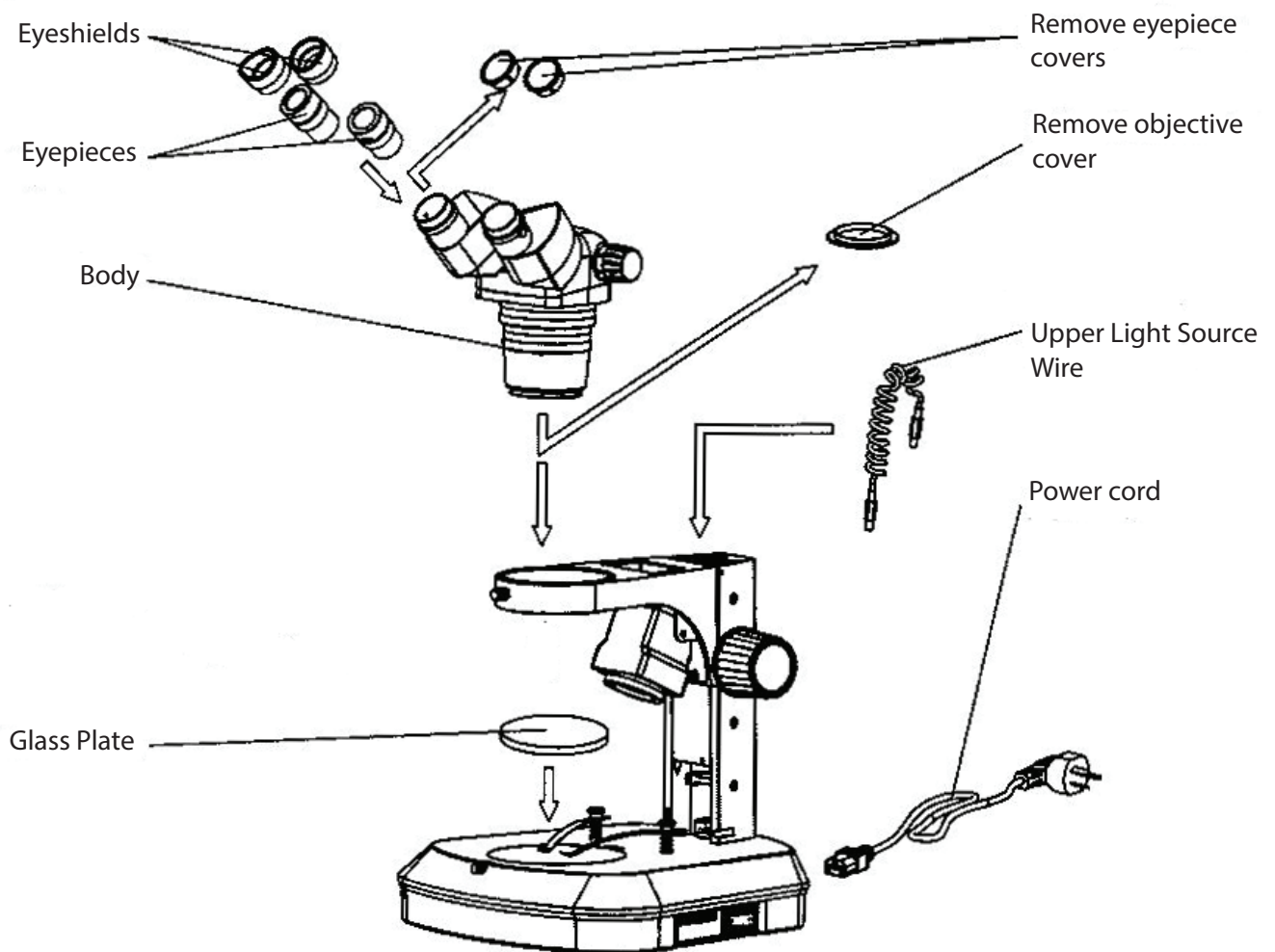

## OPERATION

1. Illumination (only for S6-DL, S6-ILS2 & S6-TD-LED Models)
  - a. Before operating the microscope, adjust the intensity controls located on each side of the base to the minimum position. This should be done prior to each time light is turned on or off. Failure to do so will significantly shorten the life of the bulb.
  - b. Make certain that the main voltage of your microscope corresponds to the voltage of your power outlet, either 120v or 220v. Insert microscope power cord into power outlet.
  - c. The S6 on lighted LED stand includes a glass stage plate. This plate is ideal for viewing transparent specimen slides or specimens that are thin enough for light to pass through them (insect wings, plant leaves, etc.) Alternate black/white contrast plates can be used when viewing opaque objects or for dissecting.
  - d. For models S6-DL & S6-ILS2, there are rocker switches on the base of the microscope. These switches are used to turn the light on/off. The rheostat control knobs will not work if the rocker switch is in the "off" position.

## 2. Interpupillary Adjustment

This will permit each user to adjust the spacing between eyepieces to accommodate distance between their eyes. While looking through the microscope eyepieces with both eyes, grasp eyepiece tube housings with both hands and rotate them, moving eyepieces apart or together until a full field of view is observed and the images blend into one. Interpupillary distance is now corrected for your own inter-ocular distance and does not require further adjustment unless another user changes the adjustment.

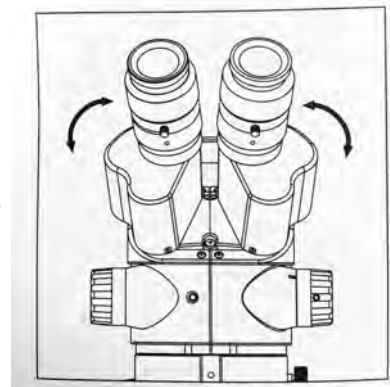

## 3. Focusing

- a. Adjust zoom control knobs (located on both sides of the head) so that the lowest magnification number "0.7" is positioned at the white notch index on head. Lower magnifications have larger fields of view, making it easier to position and locate area to be viewed.
- b. Place object on stage plate.

Focusing Continued:

- c. Position focusing knobs in the center of focusing range.
- d. Use included allen key to lock and set magnification if desired.
- d. On mounted post models, the height of the viewing head can be adjusted up or down on the post in order to focus on different sized objects. Loosen the locking knob located on the locking support collar, allowing the support collar to slide down to bottom of post. While firmly holding focusing holder containing viewing head with one hand, loosen locking knob located on back of focusing holder so that head can move freely up or down on post.

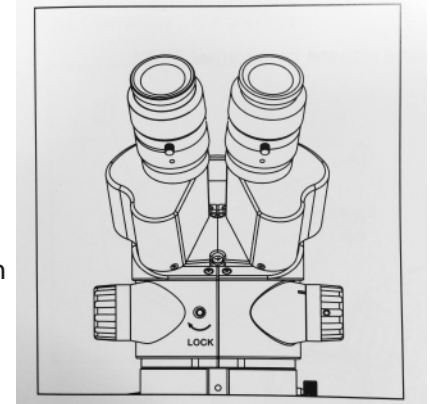

While looking through microscope, move viewing head up or down on post until object can be seen in approximate focus. Tighten focusing holder locking knob. Position the support collar under the focusing block and tighten locking knob on support collar. It is not necessary to make this adjustment every time you change objects to be viewed, so long as the different objects are of similar thickness or height.

- e. On models with lighted post stands, the up/down movement of the viewing head is limited to the traverse permitted by the regular focusing knobs.
- f. Both eyepieces have a knurled diopter adjustment ring. Rotate the diopter until the zero (0) lines up with the notch on the diopter.
- g. Adjust zoom control to the highest magnification by aligning the number "4.5" on the zoom knob.
- h. While looking through the right eyepiece with one eye, rotate focusing knob until specimen comes into sharp focus through the right eyepiece.
- i. Adjust zoom control knob to the lowest magnification.
- j. Adjust the right diopter until the image is sharp. Do not change the focusing knob position. Repeat to adjust the right diopter.
- k. The image should now be sharp throughout the zoom power range.

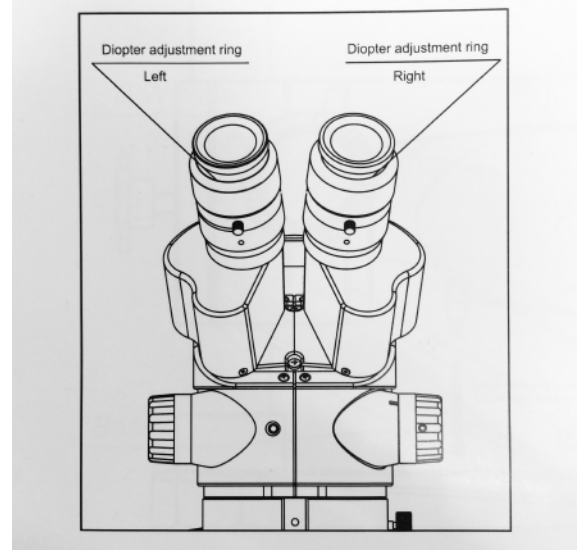

## MAINTENANCE

**WARNING: For your own safety, turn switch off and remove plug from power source before maintaining your microscope. If the power cord is worn, cut or damaged in any way, have it replaced immediately to avoid shock or fire hazard.**

1. Optical Maintenance
  - a. Do not attempt to disassemble any lens components. Consult a microscope service technician when any repairs not covered by instructions are needed.
  - b. Prior to cleaning any lens surface, brush dust or lint off lens surface using a camel hair brush. You can also use an ear syringe or canned compressed air, sold by computer stores.
  - c. To clean eyepiece lenses, do not remove from eyepiece tube. Clean only the outer lens surface. Breathe on lens to dampen surface, then wipe with lens paper or use a cotton swab moistened with distilled water. Wipe lenses with a circular motion, applying as little pressure as possible. Avoid wiping dry lens surface as lenses are scratched easily. If excessive dirt or grease gets on lens surfaces, a small amount of Windex can be used on a cotton swab or lens tissue. To clean objective lenses, do not remove objectives from microscope. Clean front lens element only, following same procedure.

2. Mechanical Maintenance

The only mechanical adjustment the microscope might require is the tension of the focusing mechanism. This has been adjusted at the factory, but over the course of time it may loosen and cause the head of the microscope to slip downward on the focusing block.

The tension adjustment collar is located between arm and focus knob on left side of microscope when the stage is facing towards you. With a jewelers type screwdriver, loosen slotted set screw located on knurled surface of the tension adjustment collar. Turn collar clockwise to tighten tension, counter-clockwise to loosen tension. After adjusting, tighten set-screw to lock collar into place.

NOTE: It is recommended that you leave the tension as loose as possible for ease of focusing, yet not so loose that it permits the head of the microscope to drift downward from its own weight and cause the microscope to “drift” out of focus.

**TROUBLESHOOTING**

<b>Problem</b>	<b>Reason for Problem</b>	<b>Solution</b>
<b>OPTICAL SYSTEM</b>		
Too Bright / Dark	Brightness degree is not set appropriately	Adjust rheostat intensity control
Dirt in Field of View	Dirt on Specimen	Clean the sample
	Dirt on Eyepieces	Clean the Eyepieces
	Dirt on Objective Lens	Clean the Objective
	Dirt on Stage	Clean the Stage
Double Images	Incorrect Interpupillary Distance	Readjust Interpupillary Distance
	Incorrect Diopter Setting	Readjust Diopters
	Two Different Magnification Eyepieces	Insert Same Eyepieces
Unclear Image	Dirt on Objective Lens	Clean the Objective
Images Blurs on Zoom	Incorrect Diopter Setting	Readjust Diopters
	Incorrect Working Distance or Focusing Setting	Check Working Distance & Focusing
<b>FOCUSING UNIT</b>		
Focusing Knob is Stiff	Focusing Knob Tension is Too Tight	Loosen tension*
Microscope Head is Falling	Focusing Knob Tension is Too Loose	Tighten tension*
<b>ADJUST MAGNIFICATION</b>		
Zoom Control Knob Will Not Turn	Magnification lock may be Activated	Loosen Magnification Lock Screw on Front of Microscope Body

\*Loosening & Tightening focusing tension depends on the microscope stand you have. The BL stand adjusts the focus tension by holding both focus knobs (left & right) and while holding the left steady, rotating the right knob. The ILST microscope stand focus is adjusted similarly by holding both knobs and rotating the right knob forward or back to tighten or loosen.

## EYEPIECE RETICLE INSTALLATION

The Richter Optica S6 stereo microscope widefield high-eyepoint 10x and 15x eyepieces both accept a 24mm diameter reticle. To install the reticle:

1. Remove the eyepiece from the eyetube and turn the eyepiece upside down.
2. Twist out and remove the threaded retaining ring from the bottom of the eyepiece.
3. Place the eyepiece reticle in the eyepiece with the inscription side facing the front of the eyepiece.
4. Screw the retaining ring back into the bottom of the eyepiece to hold the reticle in place.

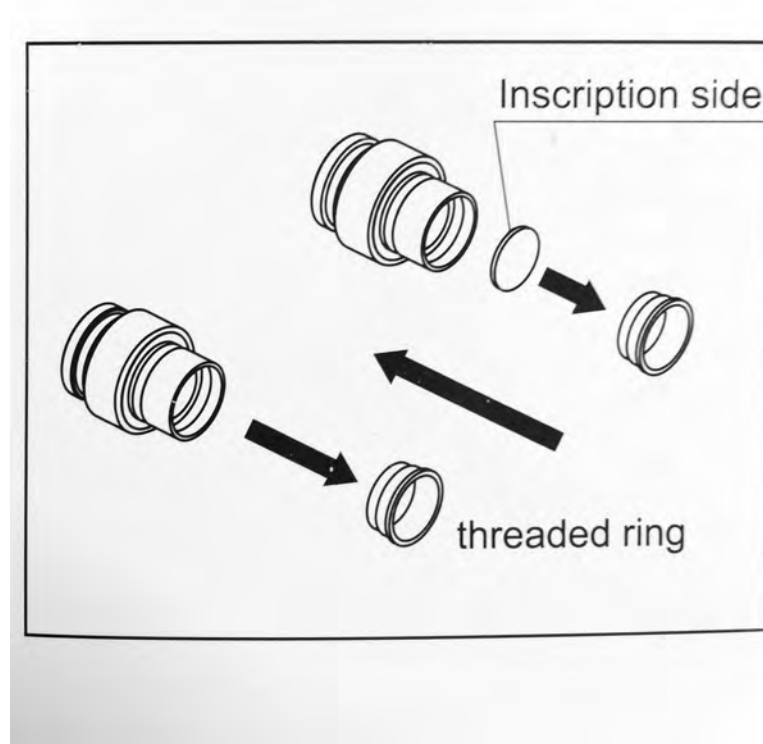



**S6 STEREO MICROSCOPE MAGNIFICATION**

The Richter Optica S6 stereo microscope can achieve different magnifications based on the eyepieces and auxiliary lenses used. Refer to the chart below in order to select the proper eyepiece and auxiliary lens accessories to meet your needs.

Auxiliary Lens	Working Distance	Eyepieces					
		Widefield 10x		Widefield 15x		Widefield 20x	
		Total Magnification	Field Size (mm)	Total Magnification	Field Size (mm)	Total Magnification	Field Size (mm)
0.5x	177mm	3.5x - 22.5x	57.1 - 8.9	5.25x - 33.75x	42.9 - 6.7	7x - 45x	28.6 - 4.4
1x (none)	100mm	7x - 45x	28.5 - 4.4	10.5x - 67.5x	21.4 - 3.3	14x - 90x	14.3 - 2.2
1.5x	47mm	10.5x - 67.5x	19 - 3	15.75x - 101.25x	14.2 - 2.2	21x - 135x	9.5 - 1.5